

Operation & Assembly Instruction

WHM-100 S/N

Art.-Nr. 24 883

1. Specification

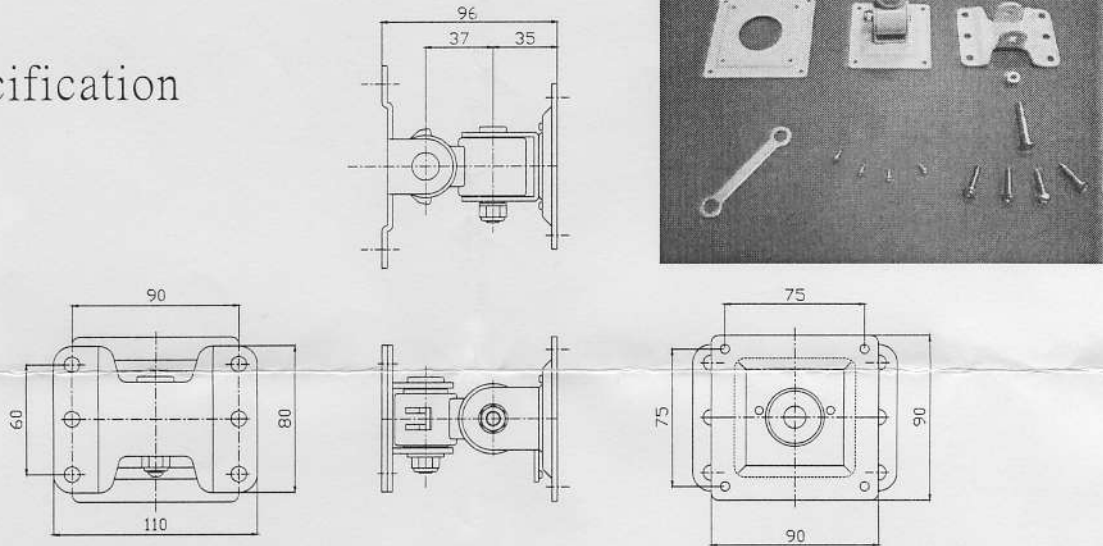

2. Installation Methods

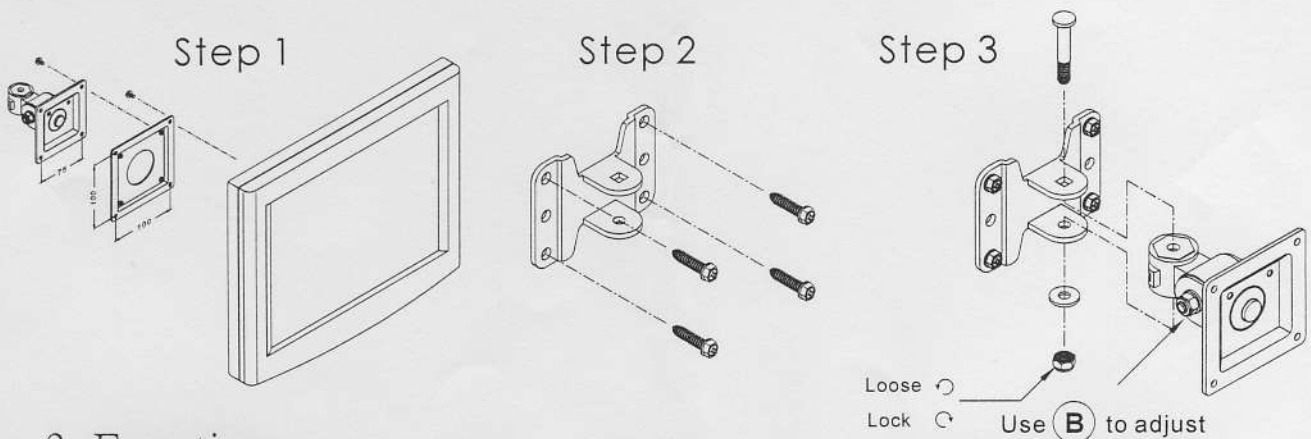

3. Functions

- 3 Directions Mini Wall mount
- Meets VESA standard(75x75, 100x100 mm)
- Weight: 0.5kg Long: 96mm
Loading: 15kg (33lbs)
- Pivot upwards & downwards: 180 degrees
- Swivel left & right: 90 degrees
- LCD monitor swivel: 180 degrees

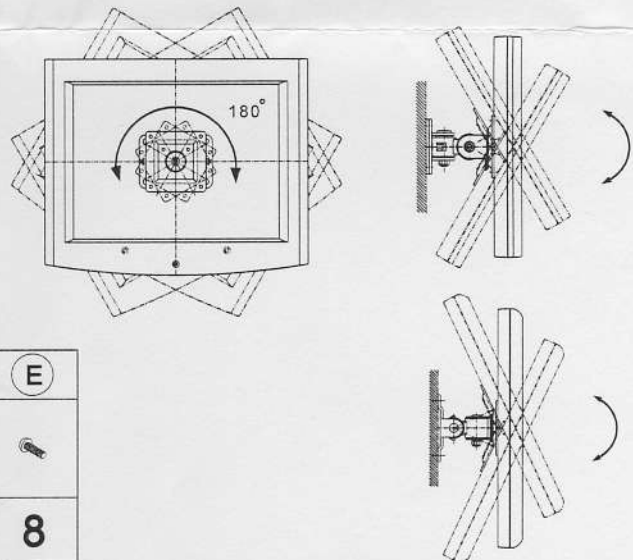

ITEM	(A)	(B)	(C)	(D)	(E)
PARTS					
QTY	1	1	4	4	8